

MULTILINK™

Installation and Operating Instruction

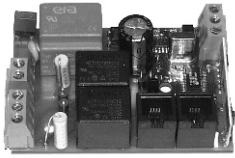

Catalog No: 6301991

DESCRIPTION

The MultiLink control provides four separate ways to drive a Somfy motor:

- Radio Remote Control using Telis transmitters, Decora RTS Switches, or Chronis Timers
- Infrared Remote Control with Somfy's 24 Channel IR Transmitter
- Manually using a low voltage switch
- Remotely by external automation device via RS232 Interface

INSTALLATION GUIDELINES

The following guidelines must be applied when installing a MultiLink control:

- The MultiLink must NOT be installed in a metal enclosure, and there should only be one control per enclosure. Failure to follow this guideline will dramatically reduce radio reception.
- The antenna MUST protrude outside of the enclosure and should not be close to high voltage wires.
- For best radio reception, the MultiLink should be installed at or above the height of the motor.
- When installing multiple controls, each control must be separated by 12 inches minimum.
- When installing multiple controls, it is recommended having only 1 MultiLink powered at a time during programming.
- The MultiLink can memorize up to 4 Telis Transmitter (or similar) channels.
- The MultiLink can memorize up to 4 Infrared Transmitter channels.

WIRING DIAGRAM

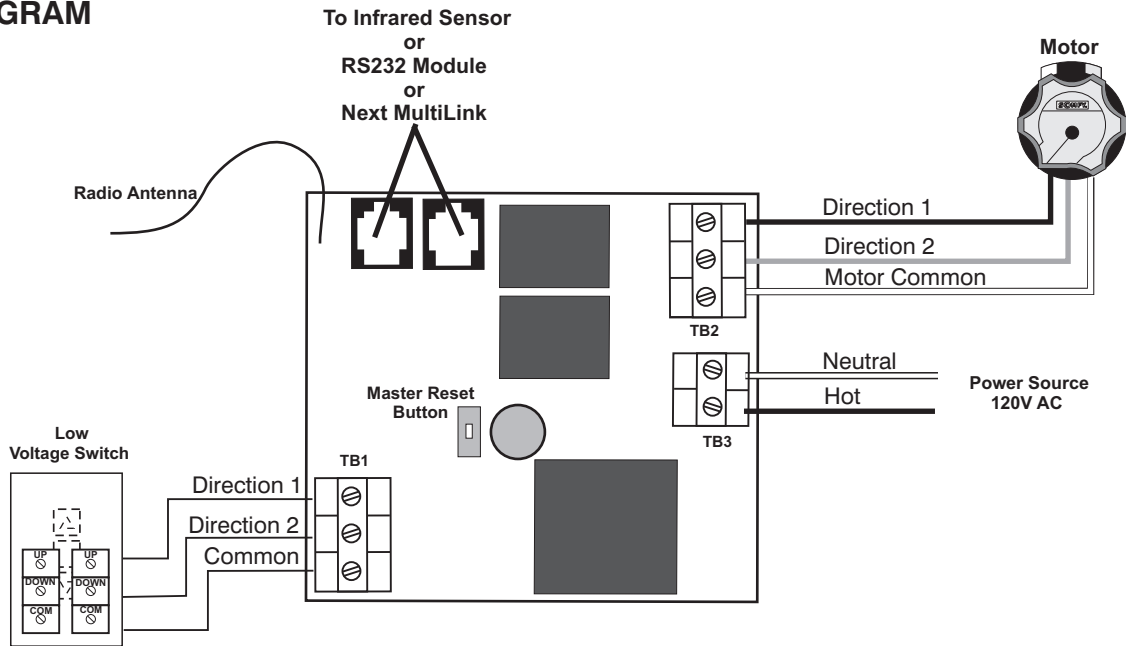

LOW VOLTAGE SWITCH OPERATION

1

VERIFY MOTOR DIRECTION

This step MUST be performed prior to any transmitters being memorized!

1. Press and release the DOWN button on the low voltage switch. The motorized window treatment should begin to lower.
2. If this is incorrect, press and hold the STOP button for two seconds. The window treatment will jog UP then DOWN.
3. To reverse directions again, simply repeat above step.

2

NORMAL OPERATION

Upon Power-Up, the MultiLink is unprogrammed and will only respond to the Low Voltage Switch Inputs or programming commands from a transmitter

1. Pressing either the UP or DOWN buttons on the low voltage switch will move the motorized treatment in the appropriate direction.
2. If the window covering is in motion, a STOP command can be given by activating the direction of movement. For example, if the treatment is moving up, activating another UP command within the programmed run time will stop the window treatment. Alternately, it can be stopped in any position by depressing the stop button on The IGC Switch.
3. To operate the tilt function in horizontal blind applications, simply press and hold the directional button on the switch. When the desired slat angle is reached, release the directional button.

RADIO REMOTE OPERATION AND PROGRAMMING

1 VERIFY MOTOR DIRECTION

This step MUST be performed prior to any transmitters being memorized!

1. Press and release both the UP and DOWN buttons on a Telis transmitter simultaneously. The motorized treatment should jog UP then DOWN.
2. Press and hold the DOWN button, if the shading system lowers or extends, press and release the UP and DOWN buttons simultaneously again. The treatment will respond by jogging UP then DOWN.
3. If the direction is incorrect, press and release the STOP button on a Telis or similar transmitter. The window treatment will now jog UP then DOWN.
NOTE: This procedure does NOT effect motor direction via the low voltage switch input. Please see the LOW VOLTAGE SWITCH OPERATION section.

2 PROGRAMMING A CHANNEL INTO MEMORY

A. Initial Transmitter

1. Press and hold the programming button on a Telis Transmitter or similar device for 3 seconds. For four channel transmitters, ensure the desired channel is selected first. The motor will respond by jogging.
2. Press and release the programming button again on the same transmitter. The motor will respond by jogging, and that channel is now memorized and will operate the MultiLink.

B. Adding Additional Transmitters

1. Press and hold (for 3 seconds) the programming button of a Telis Transmitter already memorized by the MultiLink. The motor will respond by jogging.
2. Press and release the programming button on the new transmitter or channel. The motor will respond by jogging, and that channel is now memorized and will operate the MultiLink.
3. Repeat these steps for each additional transmitter or channel - up to 4 total - to be stored in memory. If a 5th channel or transmitter programming is attempted, the MultiLink will respond by jogging the window treatment, but any commands will be ignored.

C. Deleting Transmitters

1. Press and hold (for 3 seconds) the programming button of a Telis Transmitter already memorized by the MultiLink, but not the one to be removed. The motor will respond by jogging.
2. Press and release the programming button on the transmitter or channel to be removed from memory. The motor will respond by jogging, and that channel will no longer operate the MultiLink.

NOTE: The MultiLink will always retain at least one Transmitter/Channel in memory.

3 LIFT/TILT OPERATION

1. To lower or raise a window treatment, briefly press the UP or DOWN buttons of a Telis Transmitter or similar device.
2. To stop the treatment, press the STOP button.
- 3a. To enter TILT MODE, press the UP and STOP buttons simultaneously. Tilt Mode will remain active for 30 seconds.
- 3b. Once in Tilt Mode, press and hold the UP or DOWN buttons on a Telis Transmitter. Release the button when the desired slat angle is reached.
4. To exit Tilt Mode, press the UP and STOP buttons simultaneously. Otherwise Tilt Mode will end after 30 seconds, if no directions are activated.

NOTE: During the 30 second tilt mode, the MultiLink cannot be operated from either the infrared transmitter or Low Voltage switch inputs.

Disabling Tilt Function

1. Make sure the shade is not at the upper limit. Enter programming mode by pressing the UP and DOWN buttons of a Telis Transmitter simultaneously. The window treatment will respond by jogging UP then DOWN.
2. Press and release the UP button 3 times, pausing after each switch press to verify the motor jogs UP. Press and release the STOP button, the shade will respond by Jogging. The Tilt function described above is now disabled. This will also effect the Low Voltage Switch Inputs.
3. To re-enable the tilt function, simply repeat steps 1 & 2 above.

RADIO REMOTE OPERATION AND PROGRAMMING

4 INTERMEDIATE POSITION

A. Setting the Intermediate Position

1. Enter programming mode by pressing the UP and DOWN buttons of a Telis Transmitter simultaneously. The window treatment will respond by jogging UP then DOWN.
2. Press and release the UP button then press and release the STOP button. The shade will respond by lowering to its bottom limit.
3. After the window treatment reaches its lower limit, press and release the UP button on the Telis Transmitter. The shade will begin to raise.
4. Press the STOP button on the Transmitter when the desired intermediate position is reached. The motor will stop, then respond by jogging UP then DOWN.
5. The intermediate position can be changed at any time by repeating steps 1 - 4 above.

B. Reaching the Intermediate Position

When the motor is at rest, press the STOP button on a Telis Transmitter. The window treatment will lower to its bottom limit and pause. After the programmed run time, it will raise to the programmed position.

C. Disabling the Intermediate Position

1. Make sure the window treatment is not at its upper limit. Enter programming mode by pressing the UP and DOWN buttons of a Telis Transmitter simultaneously. The window treatment will respond by jogging UP then DOWN.
2. Press and release the UP button 6 times, pausing after each switch press to verify the motor jogs UP. Press and release the STOP button, the shade will respond by jogging. The Intermediate Position is now disabled. This procedure also effects the Low Voltage Switch Inputs.

D. Clearing the Intermediate Position

In order to clear the programmed Intermediate Position, a Memory Clear command must be performed.

5 SEQUENCE OR UP/STOP/DOWN OPERATION

A. UP/STOP/DOWN Operation

Normal operation of the Low Voltage Switch Inputs of the MultiLink, upon power-up, is UP/STOP/DOWN operation. This means a momentary contact between DIRECTION1 and COMMON will activate the UP command. Similarly, connecting the DIRECTION2 and COMMON terminals will activate a DOWN command. If the window covering is in motion, a STOP command can be given by activating the direction of movement. For example, if the treatment is moving up, activating another UP command within the programmed run time will stop the window treatment. Alternately, a momentary contact closure between all three terminals (DIRECTION1, DIRECTION2, COMMON) will also activate a stop.

B. Changing to Sequence Operation

1. Make sure the shade is not at its upper limit. Enter programming mode by pressing the UP and DOWN buttons of a Telis Transmitter simultaneously. The window treatment will respond by jogging UP then DOWN.
2. Press and release the UP button 5 times, pausing after each switch press to verify the motor jogs UP. Press and release the STOP button, the shade will respond by jogging. The operation of the low voltage switch inputs ONLY will now change to Sequencing.
3. To return to UP/STOP/DOWN operation, simply repeat steps 1 & 2.

C. Sequence Operation

NOTE: the tilt function and intermediate position are disabled during sequence operation

In Sequencing Operation, each switch press will cycle through the directions as follows:

DEPRESS 1: UP DIRECTION
DEPRESS 2: STOP DIRECTION
DEPRESS 3: DOWN DIRECTION
DEPRESS 4: STOP DIRECTION

RADIO REMOTE OPERATION AND PROGRAMMING

6 RUN TIME

The motor outputs of the MultiLink, upon power-up, will turn on for a period of 2 minutes when activated in Maintained Output mode. In other words, when a direction is activated, the motor will run for 2 minutes unless a STOP command is given. This run time can be adjusted to 1 minute, 30 seconds or 15 seconds if desired.

Changing the Run Time

1. Make sure the shade is not at the upper limit. Enter programming mode by pressing the UP and DOWN buttons of a Telis Transmitter simultaneously. The window treatment will respond by jogging UP then DOWN.
2. Press and release the UP button 7 times, pausing after each switch press to verify the motor jogs UP. Press and release the STOP button, the shade will respond by Jogging.
3. Press and release the DOWN button a number of times to select the following run times:
 - Once for 15 seconds
 - Twice for 30 seconds
 - 3 times for 1 minute
 - 4 times for 2 minutes
4. Press and release the STOP button. The motor will respond by jogging indicating the run time is saved.
5. To change the run time, simply repeat steps 1 through 4 above.

7 MOMENTARY OR MAINTAINED OUTPUTS

Normal operation of the MultiLink, upon power-up, is Maintained Outputs. This means the switch button needs only to be pressed and released for the action to take. A Momentary Output requires the button to be pressed and held for the duration of the desired movement.

Changing Output Mode

1. Make sure the shade is not at the upper limit. Enter programming mode by pressing the UP and DOWN buttons of a Telis Transmitter simultaneously. The window treatment will respond by jogging UP then DOWN.
2. Press and release the UP button 2 times, pausing after each switch press to verify the motor jogs UP. Press and release the STOP button, the shade will respond by jogging. The outputs are now changed to Momentary, when operated from the Low Voltage Switch Inputs ONLY.
3. To re-enable the Maintained Outputs, simply repeat steps 1 & 2.

8 MEMORY CLEAR

THIS STEP ERASES ALL MEMORIZED TRANSMITTER CHANNELS AND PROGRAMMED FUNCTIONS!

1. Make sure the shade is not at its upper limit. Enter programming mode by pressing the UP and DOWN buttons of a Telis Transmitter simultaneously. The window Treatment will respond by jogging UP then DOWN.
2. Press and release the UP button 4 times, pausing after each switch press to verify the motor jogs UP. Press and release the STOP button, the shade will respond by Jogging. All transmitters and functions are now deleted from memory.
3. Alternately, the memory can be cleared by pressing the Memory Clear button on the Control Board.

INFRARED REMOTE OPERATION AND PROGRAMMING

NOTE: Characters enclosed in brackets such as <X>, indicate the IR Transmitter button to be pressed.

1 VERIFY MOTOR DIRECTION

This step MUST be performed prior to any transmitters being memorized!

1. Press and release the following buttons on a Somfy 24 Channel Infrared Transmitter: <G1> <G2> <G3> <ALL> <ALL>. The motorized treatment should jog UP then DOWN.
2. Press and hold the DOWN button, if the shading system lowers or extends, press and release the <ALL> button. The treatment will respond by jogging UP then DOWN.
3. If the direction is incorrect, press and release the STOP button on the IR transmitter. The window treatment will now jog UP then DOWN.

NOTE: This procedure does NOT effect motor direction via the low voltage switch input. Please see the LOW VOLTAGE SWITCH OPERATION section.

2 PROGRAMMING A CHANNEL INTO MEMORY

A. Programming the First Channel

1. Press and release the following buttons on a Somfy 24 Channel Infrared Transmitter: <G1> <G2> <G3> <ALL> <ALL>. The control is now in programming mode and the motor will respond by jogging.
2. Press and release <1>, then the channel to be memorized.
3. Press and release the <ALL> button, the motor will respond by jogging and that channel will now operate the MultiLink.

B. Programming Additional Channels

1. Press and release the button(s) of a channel that is already programmed into memory.
2. Press and release the following buttons on a Somfy 24 Channel Infrared Transmitter: <G1> <G2> <G3> <ALL> <ALL>. The control is now in programming mode and the motor will respond by jogging.
3. Press and release <1>, then the channel to be memorized.
4. Press and release the <ALL> button, the motor will respond by jogging and that channel will now operate the MultiLink.
5. Repeat these steps for each transmitter channel - up to 4 total - to be stored in memory. If a 5th channel programming is attempted, the MultiLink will respond by jogging, but any commands will be ignored.

Examples:

After entering programming mode enter the following transmitter button sequences:

To memorize channel 1: <1> <1> <ALL>

To memorize channel 99: <1> <9> <9> <ALL>

To memorize channel 23: <1> <23> <ALL> or <1> <2> <3> <ALL> NOTE: if <2> <3> is memorized, the control must be addressed the same way.

C. Deleting Channels

1. Press and release the button(s) of a channel that is already programmed into memory.
2. Press and release the following buttons on a Somfy 24 Channel Infrared Transmitter: <G1> <G2> <G3> <ALL> <ALL>. The control is now in programming mode and the motor will respond by jogging.
3. Press and release <4>, then the channel to be deleted.
4. Press and release the <ALL> button, the motor will respond by jogging and that channel will no longer operate the MultiLink.

3 LIFT/TILT OPERATION

1. To lower or raise a window treatment, briefly press the desired unit number, then the UP or DOWN buttons of the Infrared Transmitter.
2. To stop the treatment, press the STOP button.
3. To tilt a horizontal blind, press and hold the UP or DOWN buttons on the Transmitter. Release the button when the desired slat angle is reached.

Disabling Tilt Function

1. Press and release the button(s) of a channel that is already programmed into memory.
2. Press and release the following buttons on a Somfy 24 Channel Infrared Transmitter: <G1> <G2> <G3> <ALL> <ALL>. The control is now in programming mode and the motor will respond by jogging.
3. Press and release <16>. NOTE: the "16" key must be pressed, pressing <1> then <6> will not perform the desired function.
4. The motor will respond by jogging. The Tilt function described above will no longer operate. This procedure will also effect the Low Voltage Switch Inputs.
5. To re-enable the tilt function, simply repeat steps 1 - 3 above.

INFRARED REMOTE OPERATION AND PROGRAMMING

4

MOMENTARY OR MAINTAINED OUTPUTS

Normal operation of the MultiLink, upon power-up, is Maintained Outputs. This means the switch button needs only to be pressed and released for the action to take. A Momentary Output requires the button to be pressed and held for the duration of the desired movement.

Changing Output Mode

1. Press and release the button(s) of a channel that is already programmed into memory.
2. Press and release the following buttons on a Somfy 24 Channel Infrared Transmitter: <G1> <G2> <G3> <ALL> <ALL>. The control is now in programming mode and the motor will respond by jogging.
3. Press and release <11>. NOTE: the "11" key must be pressed, pressing <1> then <1> will not perform the desired function.
4. The motor will respond by jogging. The outputs are now changed to Momentary, when operated from the Low Voltage Switch Inputs ONLY.
5. To re-enable the Maintain Outputs, simply repeat steps 1 - 3 above.

5

INTERMEDIATE POSITION

A. Setting the Intermediate Position

1. Press and release the button(s) of a channel that is already programmed into memory.
2. Press and release the following buttons on a Somfy 24 Channel Infrared Transmitter: <G1> <G2> <G3> <ALL> <ALL>. The control is now in programming mode and the motor will respond by jogging.
3. Press and release <6>, the shade will respond by lowering to its bottom limit.
4. After the window treatment reaches its lower limit, press and release the UP button on the IR Transmitter. The shade will begin to raise.
5. Press the STOP button on the Transmitter when the desired intermediate position is reached. The motor will stop, then respond by jogging UP then DOWN.
6. The intermediate position can be changed at any time by repeating steps 1 - 5 above.

B. Reaching the Intermediate Position

When the motor is at rest, press the STOP button on an IR Transmitter. The window treatment will lower to its bottom limit and pause. After the programmed run time, it will raise to the programmed position.

C. Disabling the Intermediate Position

1. Press and release the button(s) of a channel that is already programmed into memory.
2. Press and release the following buttons on a Somfy 24 Channel Infrared Transmitter: <G1> <G2> <G3> <ALL> <ALL>. The control is now in programming mode and the motor will respond by jogging.
3. Press and release <23>. NOTE: the "23" key must be pressed, pressing <2> then <3> will not perform the desired function.
4. The shade will respond by jogging. The intermediate position is now disabled. This procedure will also effect the Low Voltage Switch Inputs.
5. To re-enable the intermediate position, simply repeat steps 1 - 3 above.

D. Clearing the Intermediate Position

In order to clear the programmed Intermediate Position, a Memory Clear command must be performed.

6

SEQUENCE OR UP/STOP/DOWN OPERATION

A. UP/STOP/DOWN Operation

Normal operation of the Low Voltage Switch Inputs of the MultiLink, upon power-up, is UP/STOP/DOWN operation. This means a momentary contact between DIRECTION1 and COMMON will activate the UP command. Similarly, connecting the DIRECTION2 and COMMON terminals will activate a DOWN command. If the window covering is in motion, a STOP command can be given by activating the direction of movement. For example, if the treatment is moving up, activating another UP command within the programmed run time will stop the window treatment. Alternately, a momentary contact closure between all three terminals (DIRECTION1, DIRECTION2, COMMON) will also activate a stop.

B. Changing to Sequence Operation

1. Press and release the button(s) of a channel that is already programmed into memory.
2. Press and release the following buttons on a Somfy 24 Channel Infrared Transmitter: <G1> <G2> <G3> <ALL> <ALL>. The control is now in programming mode and the motor will respond by jogging.
3. Press and release <7>, the motor will respond by jogging. The operation of the Low Voltage Switch Inputs ONLY will now change to Sequencing.
4. To return to UP/STOP/DOWN operation, simply repeat steps 1 - 3 above.

C. Sequence Operation

NOTE: the tilt function and intermediate position are disabled during sequence operation

In Sequencing Operation, each switch press will cycle through the directions as follows:

- DEPRESS 1: UP DIRECTION
- DEPRESS 2: STOP DIRECTION
- DEPRESS 3: DOWN DIRECTION
- DEPRESS 4: STOP DIRECTION

INFRARED REMOTE OPERATION AND PROGRAMMING

7 RUN TIME

The motor outputs of the MultiLink, upon power-up, will turn on for a period of 2 minutes when activated in Maintained Output mode. In other words, when a direction is activated, the motor will run for 2 minutes unless a STOP command is given. This run time can be adjusted to 1 minute, 30 seconds or 15 seconds if desired.

Changing the Run Time

1. Press and release the button(s) of a channel that is already programmed into memory.
2. Press and release the following buttons on a Somfy 24 Channel Infrared Transmitter: <G1> <G2> <G3> <ALL> <ALL>. The control is now in programming mode and the motor will respond by jogging.
3. Press and release <18>. NOTE: the "18" key must be pressed, pressing <1> then <8> will not perform the desired function.
4. Press and release one of the following buttons to select the indicated run time:
 - <1> for 15 seconds
 - <2> for 30 seconds
 - <3> for 1 minute
 - <4> for 2 minutes
5. Press and release the <ALL> button. The motor will respond by jogging indicating the run time is saved.
6. To change the run time, simply repeat steps 1 through 5 above.

8 PULSE TIME

The PULSE TIME is defined as the maximum time a signal can appear on the low voltage switch inputs before activating the tilt operation. Normal operation of the MultiLink, upon power-up, is 1/2 second. In other words, if a switch closure lasts longer than 1/2 second, the control will go into tilt mode. This pulse time can be adjusted to 1/4 second, 3/4 second or 1 second if desired.

Changing the Pulse Time

1. Press and release the button(s) of a channel that is already programmed into memory.
2. Press and release the following buttons on a Somfy 24 Channel Infrared Transmitter: <G1> <G2> <G3> <ALL> <ALL>. The control is now in programming mode and the motor will respond by jogging.
3. Press and release <17>. NOTE: the "17" key must be pressed, pressing <1> then <7> will not perform the desired function.
4. Press and release one of the following buttons to select the indicated pulse time:
 - <1> for 1/4 second
 - <2> for 1/2 second
 - <3> for 3/4 second
 - <4> for 1 second
5. Press and release the <ALL> button. The motor will respond by jogging indicating the pulse time is saved.
6. To change the pulse time, simply repeat steps 1 through 5 above.

9 DISABLE LOW VOLTAGE INPUTS

The Low Voltage Switch Inputs of the MultiLink can be disabled, if necessary. Keep in mind, all commands from this input will be ignored.

1. Press and release the button(s) of a channel that is already programmed into memory.
2. Press and release the following buttons on a Somfy 24 Channel Infrared Transmitter: <G1> <G2> <G3> <ALL> <ALL>. The control is now in programming mode and the motor will respond by jogging.
3. Press and release <13>. NOTE: the "13" key must be pressed, pressing <1> then <3> will not perform the desired function.
4. The motor will respond by jogging, indicating the Low Voltage Switch Inputs have been turned off.
5. To re-enable the Low Voltage switch inputs, simply repeat steps 1 - 3 above.

INFRARED REMOTE OPERATION AND PROGRAMMING

10 DISABLE RADIO REMOTE OPERATION

If the radio remote operation will not be used, it is suggested that this function be disabled.

1. Press and release the button(s) of a channel that is already programmed into memory.
2. Press and release the following buttons on a Somfy 24 Channel Infrared Transmitter: <G1> <G2> <G3> <ALL> <ALL>. The control is now in programming mode and the motor will respond by jogging.
3. Press and release <10>. NOTE: the "10" key must be pressed, pressing <1> then <0> will not perform the desired function.
4. The motor will respond by jogging, indicating the radio receiver has been turned off.
5. To re-enable radio remote operation, simply repeat steps 1 through 3 above.

11 MEMORY CLEAR

THIS STEP ERASES ALL MEMORIZED TRANSMITTER CHANNELS AND PROGRAMMED FUNCTIONS!

1. Press and release the button(s) of a channel that is already programmed into memory.
2. Press and release the following buttons on a Somfy 24 Channel Infrared Transmitter: <G1> <G2> <G3> <ALL> <ALL>. The control is now in programming mode and the motor will respond by jogging.
3. Press and release <22>. NOTE: the "22" key must be pressed, pressing <2> then <2> will not perform the desired function.
4. The motor will respond by jogging. All transmitters and functions are now deleted from memory.
5. Alternately, the memory can be cleared by pressing the Memory Clear button on the Control Board.

12 RS232 COMPATIBILITY

The MultiLink Control can be operated by a home automation system via RS232 communication. Somfy's MultiChannel RS232 Interface (Part Number 6301232) is simply connected to either modular connector on the MultiLink. A graphic user interface (GUI) available from Somfy will emulate the appearance of the 24 Channel Infrared Transmitter. All options noted above can be programmed from the GUI by following the same steps.

SOMFY CANADA

6315 Shawson Drive, Unit #1
Mississauga, Ontario L5T1J2

SOMFY SYSTEMS, INC.

47 Commerce Drive
Cranbury, NJ 08512

SOMFY MEXICO S.A. De C.V.

Calle 3 No.47, Loc.E-5
Fracc Ind. Alce Blanco
Nau.,Edo. de Mex C.P. 53370,Mex

SOMFY SYSTEMS, INC. reserves the right to change, update or improve this document without prior notice.

Ref. No. 2500991 Rev. B

© SOMFY SYSTEMS, INC. 7/05

MULTILINK™

Quick Reference Guide

INFRARED OPERATION

- A. Motor direction MUST be verified before any transmitters or functions are programmed.
- C. To Enter Programming Mode; the following keys MUST be pressed on the Somfy 24 Channel IR Transmitter:
 <G1> <G2> <G3> <ALL> <ALL>
- D. After entering programming mode, a function code is entered. The following is a summary of all the programmable functions, their key strokes and default values.

1 FUNCTIONS AVAILABLE BEFORE THE FIRST CHANNEL IS PROGRAMMED

KEY PRESS	FUNCTION
UP/DOWN	Verify Motor Direction
STOP	Reverse Direction
1	Save First Channel or Transmitter in Memory

2 FUNCTIONS AVAILABLE AFTER THE FIRST CHANNEL IS PROGRAMMED

KEY PRESS	FUNCTION	DEFAULT VALUE
1	Save a Channel or Transmitter in Memory	
4	Delete a Transmitter or Channel from Memory	
6	Enter Intermediate Position Setup	
7	Program switch inputs to UP/STOP/DOWN or Sequence	UP/STOP/DOWN
10	Disable or Enable Radio Operation	Enabled
11	Make outputs Momentary or Maintained	Maintained
13	Disable or Enable Low Voltage Switch Inputs	Enabled
16	Disable or Enable Tilt Mode	Enabled
17	Program Switch Input Pulse time	1/2 second
	1: 1/4 second	
	2: 1/2 second	
	3: 3/4 second	
	4: 1 second	
18	Program Run Time	2 minutes
	1: 15 seconds	
	2: 30 seconds	
	3: 1 minute	
	4: 2 minutes	
22	Erase all programmed functions and memorized transmitters	
23	Disable/Enable Intermediate Position	Enabled

RADIO OPERATION

- A. Motor direction **MUST** be verified before any transmitters or functions are programmed.
- B. To enter programming mode, first ensure the window treatment is not at the upper limit. Press the UP and DOWN buttons on a Telis Transmitter or similar device. The motor will jog.
- C. After entering programming mode, The UP button of the transmitter will be pressed a number of times followed by the STOP button, dependent on the function. The motor will jog each time the UP button is pressed. Below is a summary of the number of UP key presses and the corresponding function.
- D. Master Reset can be performed by pressing the reset button on the control board or via the transmitter.

1

FUNCTIONS AVAILABLE BEFORE THE FIRST CHANNEL IS PROGRAMMED

KEY PRESS	FUNCTION
UP/DOWN	Verify Motor Direction
STOP	Reverse Direction

2

FUNCTIONS AVAILABLE AFTER THE FIRST CHANNEL IS PROGRAMMED

UP KEY PRESSES	FUNCTION	DEFAULT VALUE
1	Enter Intermediate Position Setup	
2	Make outputs Momentary or Maintained	Maintained
3	Disable or Enable Tilt Function	Enabled
4	Erase all programmed functions and memorized transmitters	
5	Program switch inputs to UP/STOP/DOWN or Sequence	UP/STOP/DOWN
6	Disable or Enable Intermediate Position	Enabled
7	Set Run Time	2 Minutes

EXAMPLE: To disable the tilt function, the following buttons should be pressed:
<UP> <UP> <UP> <STOP>